

1000-BV2 BUCKET DIVERTER

Bulletin 1000.002

The **SINCLAIR** Model 1000-BV2 Two-Way Bucket Diverter Valve offers numerous advantages over traditional single-blade diverter designs. The internal bucket routes material from inlet to either discharge, and the side wings of the bucket design guarantee that all of the product goes to the correct leg.

Advantages of the 1000-BV2 include:

- Positive routing of material
- Material can not leak to wrong discharge
- Less actuator torque required
- Material cannot jam between blade edge and housing
- Bucket can be serviced or replaced with diverter in place.

All sizes of the 1000-BV2 come equipped with shaft seals, "SQA" access doors, bucket service door, heavy-duty shaft support bearings and AR-235 Bhn diverter bucket.

Standard construction also includes mild steel plate housing, seal-welded and gasketed dust-tight, with flanged ball bearings. **SINCLAIR** can also furnish high-temperature bearings and seals if required by the application.

The standard actuator for the 1000-BV2 is a shaft-mounted lever arm; alternate devices include pneumatic and hydraulic cylinder assemblies, electric linear or rotary actuators, handwheels or chainwheels.

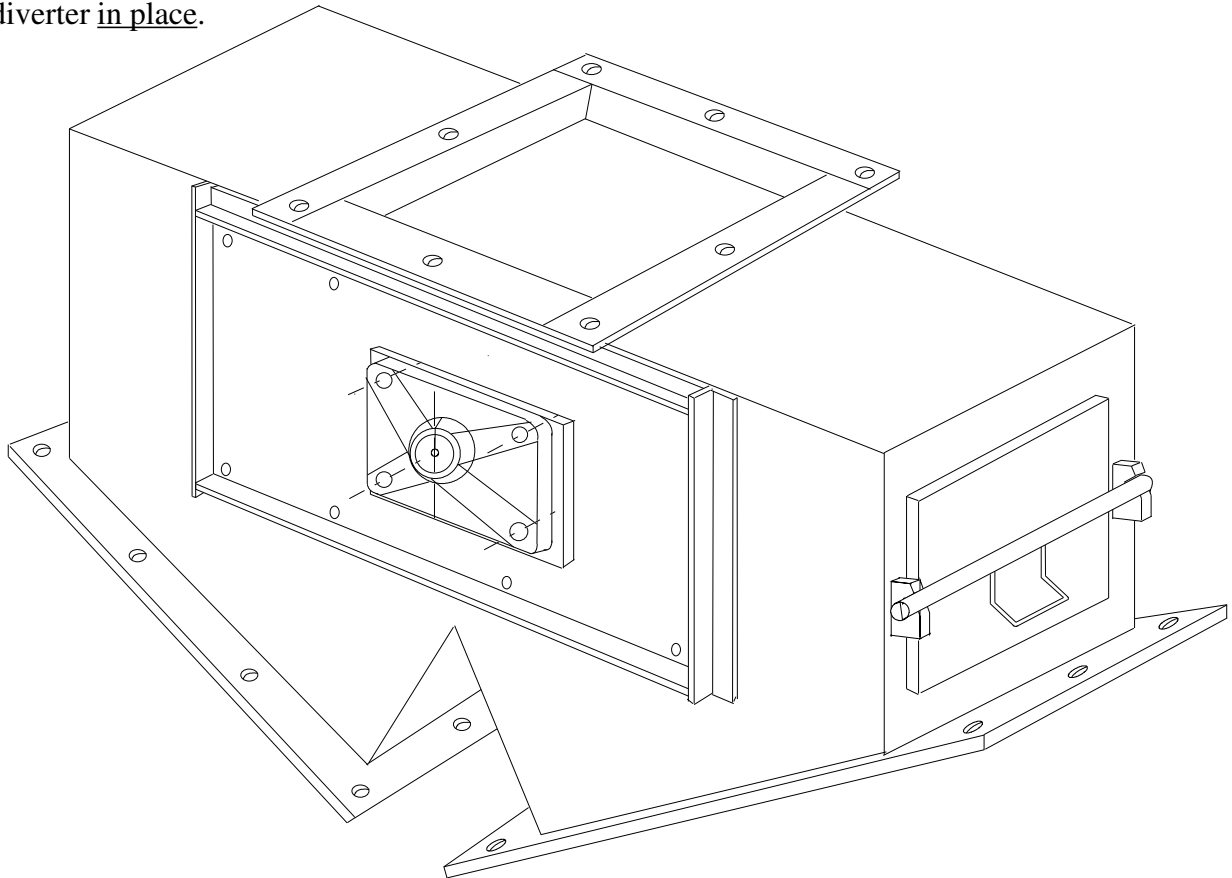

B. W. SINCLAIR, INC.

BULK MATERIAL HANDLING

P. O. Box 1111
 13923 US Hwy 287 North
 Wichita Falls TX 76307-1111
 Phone 940-766-2556
 Fax 940-766-0430
 e-mail: sales@bwsinclair.com

1000-BV2 BUCKET DIVERTER

Bulletin 1000.002

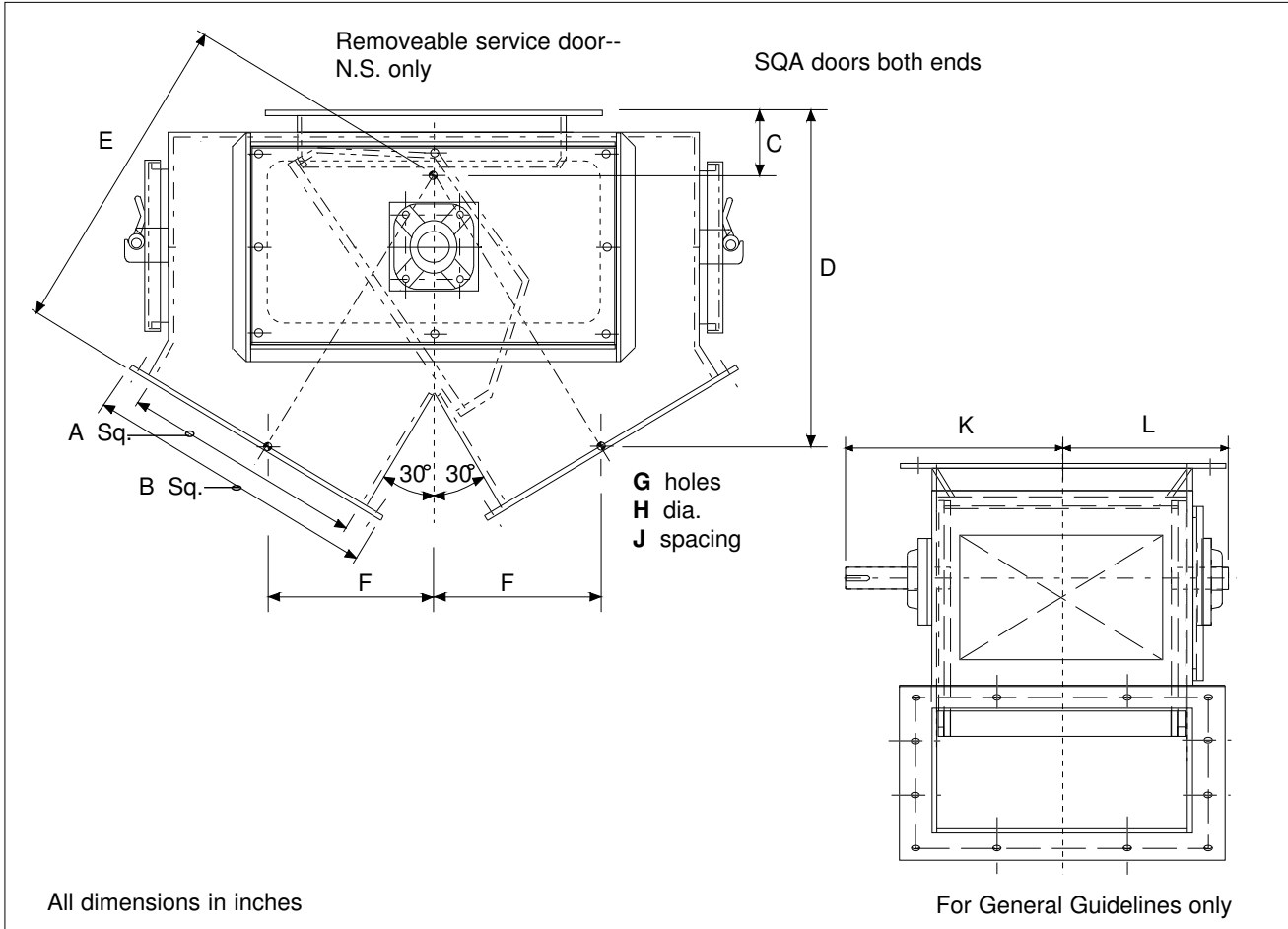

All dimensions in inches

For General Guidelines only

| Model | A | B | C | D | E | F | G | H | J | K | L |
|-------|----|--------|-------|---------|----------|---------|----|-------|-----------|---------|---------|
| 1006 | 6 | 9-1/4 | 2-1/2 | 12-1/2 | 11-9/16 | 5-3/4 | 8 | 7/16 | 2@4 | 9 | 6-7/8 |
| 1008 | 8 | 11-1/4 | 2-7/8 | 14-7/16 | 13-3/8 | 6-11/16 | 8 | 7/16 | 2@5 | 10 | 7-7/8 |
| 1010 | 10 | 13-1/4 | 3 | 16 | 15 | 7-1/2 | 12 | 7/16 | 3@4 | 11 | 8-7/8 |
| 1012 | 12 | 16-1/2 | 3-3/8 | 17-7/8 | 16-3/4 | 8-3/8 | 12 | 9/16 | 3@4-3/4 | 12-1/8 | 10 |
| 1014 | 14 | 18-1/2 | 4 | 20-5/8 | 19-3/16 | 9-9/16 | 16 | 9/16 | 4@4-3/16 | 13-1/8 | 11 |
| 1016 | 16 | 20-1/2 | 4-1/4 | 22-1/2 | 21-1/16 | 10-1/2 | 16 | 9/16 | 4@4-11/16 | 14-5/16 | 12-3/16 |
| 1018 | 18 | 22-1/2 | 4-1/2 | 24-1/4 | 22-13/16 | 11-7/16 | 16 | 9/16 | 4@5-3/16 | 15-5/16 | 13-3/16 |
| 1024 | 24 | 29-3/4 | 5-3/4 | 30-7/8 | 29 | 14-1/2 | 16 | 11/16 | 4@6-7/8 | 18-1/4 | 16-1/8 |

1000-BV2 SPECIFICATIONS:

HOUSING: Mild or stainless steel. AR plate.

BUCKET: AR-235 wear plate.

BUCKET SEAL: Fabricated steel bar stock. UHMW-PE when BV2 is stainless.

SHAFT SEALS:

ACTUATION:

INSTRUMENTS:

Polyethelene. Felt. Hi-Temp. Silicone.

Lever arm. Hand- or chain-wheel. Air or fluid power. Electric actuator.

Position-indicating limit switches. Control valves.