

## By Pass Load Diverter - Series "F"

For Pneumatic Conveying Systems Applications

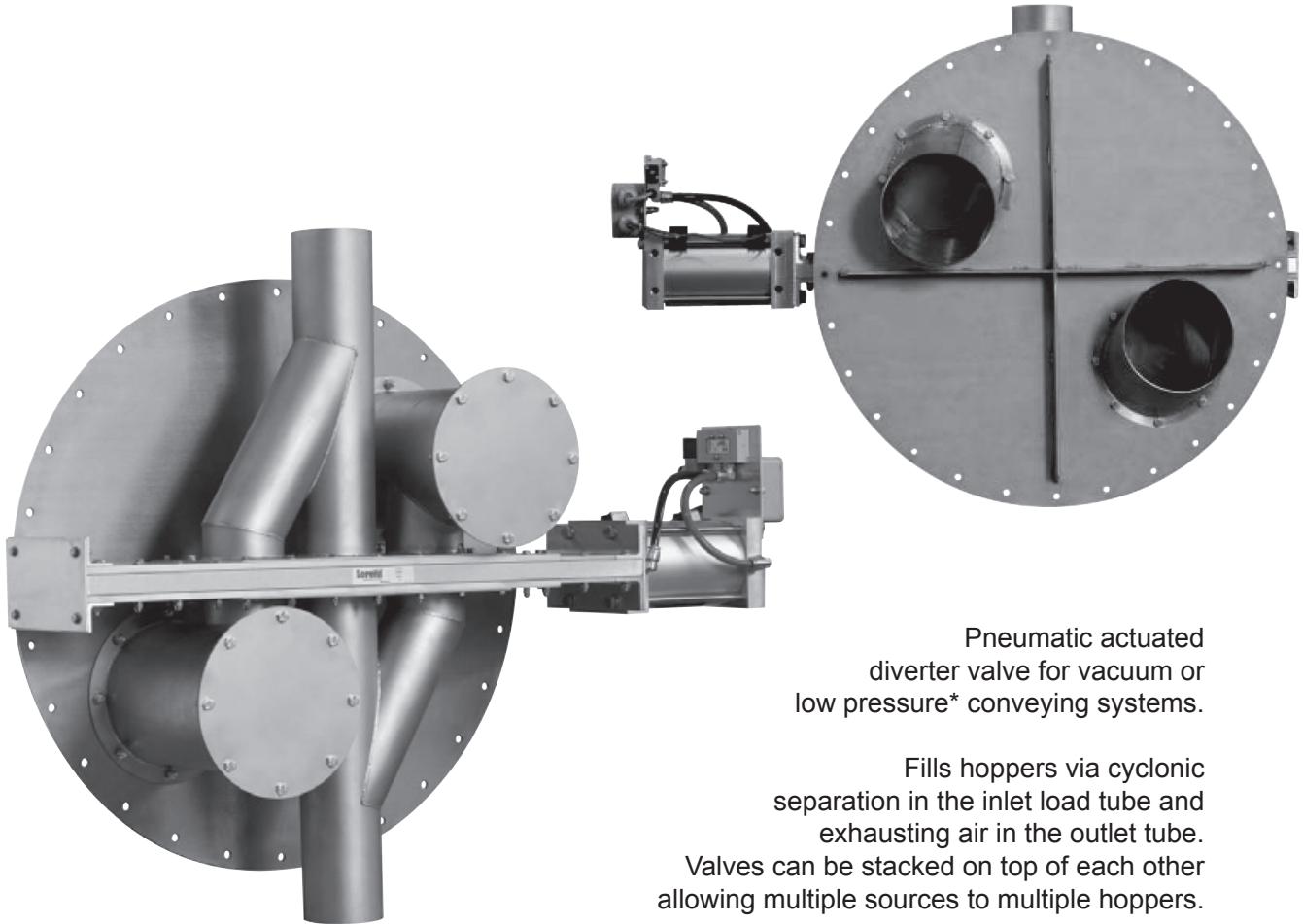

Pneumatic actuated diverter valve for vacuum or low pressure\* conveying systems.

Fills hoppers via cyclonic separation in the inlet load tube and exhausting air in the outlet tube. Valves can be stacked on top of each other allowing multiple sources to multiple hoppers.

Available in sizes 2" to 8".

(Dilute phase up to 15 psig max.)

### Standard Features

- Stainless steel construction standard - optional carbon steel & aluminum
  - Lightweight aluminum frame, corrosion resistant
  - Positive blade lock (PBL) between blade and cylinder rod
- Active compression seals (ACS) • Internal magnetic piston cushioned air cylinder
  - Stacking design for multiple conveying lines
  - Rated for 82° (180°F) • Base is sold separately

# By Pass Load Diverter - Series "F"

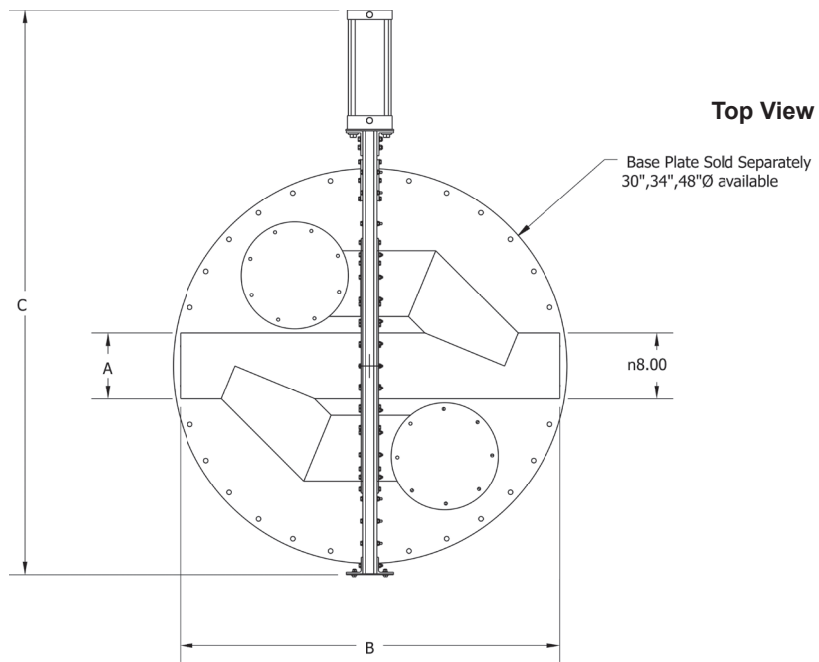

BLD				
Size	A	B	C	D
200	2.00	23.75	31.31	7.00
300	3.00	26.00	36.94	8.00
400	4.00	31.25	38.06	10.00
500	5.00	35.25	47.06	12.00
600	6.00	40.25	51.19	13.00
800	8.00	46.25	68.62	15.00
All dimensions approximate and subject to change				

## Options

- 316 stainless material contact points
- High temperature service