



Shown with C2 Process Fitting
Imperial Conduit Entry

SIMPLICITY AT ITS BEST WITH CONSISTENT RESULTS

Pulse Point™ II Series models sense when a material reaches or leaves a particular point. These point level switches use electronic vibratory technology to sense the material. This mechanical operation is not affected by the dielectric constant of the material being measured.

FEATURES AND BENEFITS

- Universal Input Power provides flexibility.
- Adjustable Time Delay allows the user to determine time between sensing material and the alarm state. Advanced units can permit delays when it detects the presence and absence of material or a combination.
- Sensitivity Settings can be selected to fit specific applications and material requirements.
- To avoid false readings, the Pulse Point II features Build-Up Detection to detect when material is beginning to build up on the forks.
- Move electronics up to 100 ft (30 m) away with the Remote Option.
- Available on Advanced units only, Liquid/Solid Interface feature can detect solids under a liquid surface.
- Standard and Advanced offering enables the user to choose the option that best suits the application.
- Frame designed to enable connection flexibility:
Imperial or Metric conduit entry options.
Process Fitting can be made to fit any connection.

STANDARD VS. ADVANCED UNITS

STANDARD	ADVANCED
3 Sensitivity Settings	6 Sensitivity Settings
Time Delay up to 6 seconds	Time Delay up to 150 seconds
Universal Power	Universal Power
	Test FOB
	Push Button Test
	Indicator Lights
	Auxiliary Relay
	Liquid/Solid Interface (Optional)
	Build-up Detection

Pulse Point™ II Fork

PULSE POINT II - STANDARD

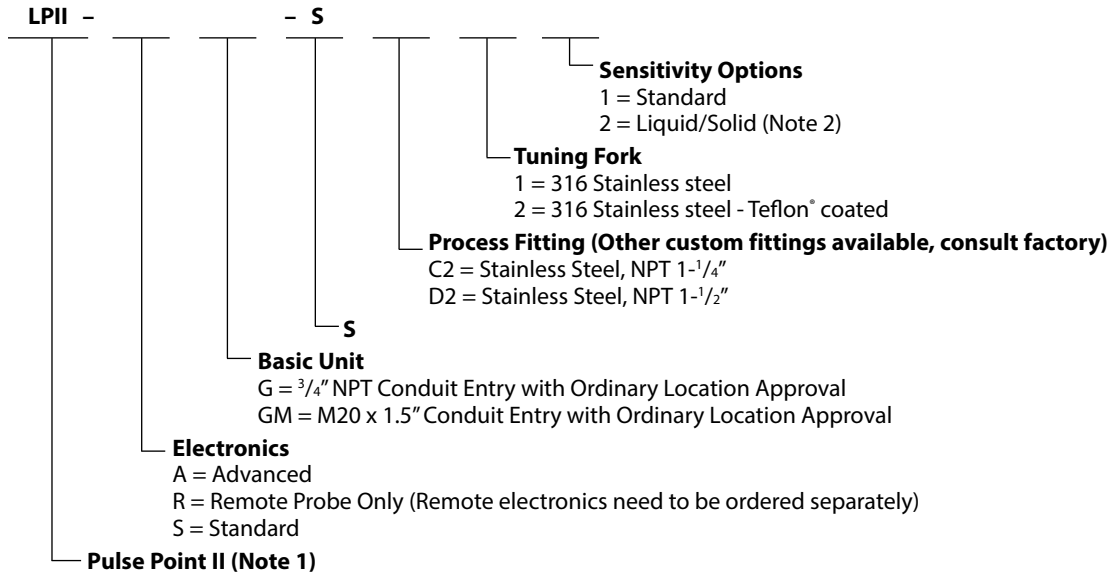

- Notes: 1. Units have Powder Coated Aluminum Housing Finish.
 2. Available on Advanced Units only.

DIMENSIONAL DRAWING - STANDARD

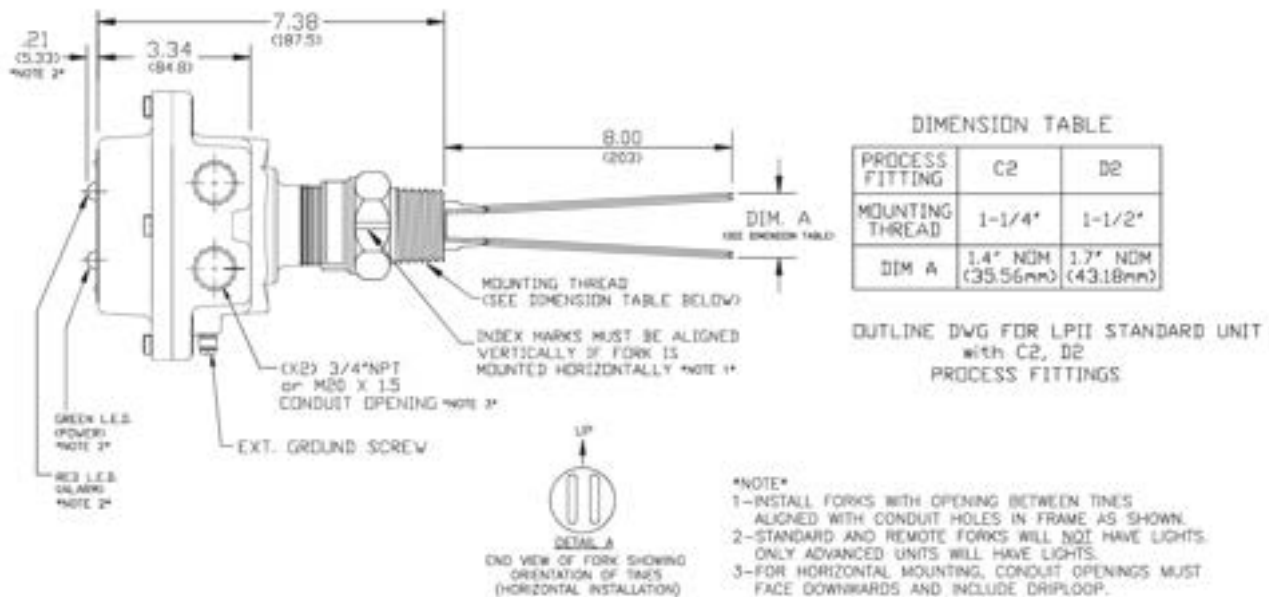

* Additional drawings available at www.bindicator.com

PULSE POINT II - EXTENSIONS

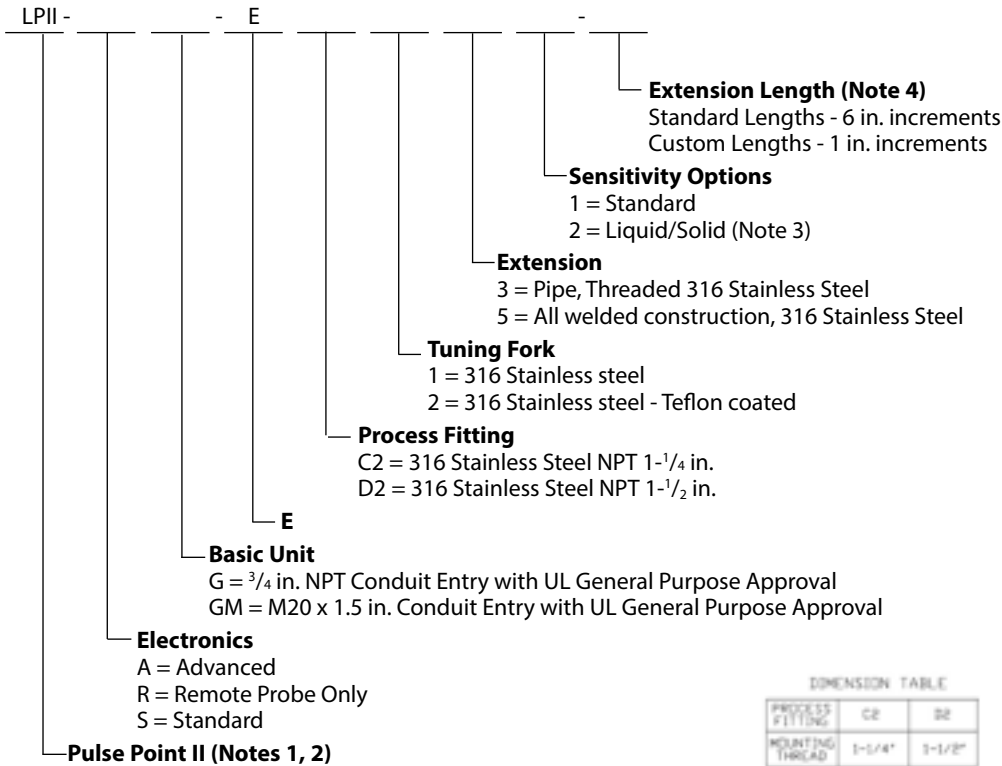

DIMENSION TABLE

PROCESS FITTING	C2	D2
MOUNTING THREAD	1-1/4"	1-1/2"

OUTLINE DWG FOR LPII PIPE EXTENDED WELDED UNIT with C2, D2 PROCESS FITTINGS

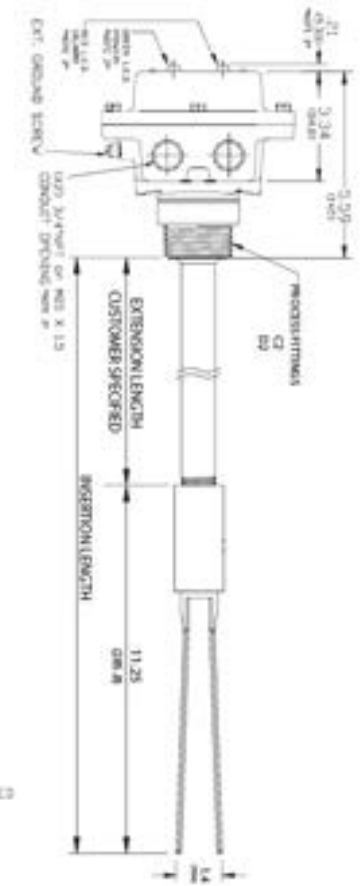

- Notes:
- Units have powder coated aluminum Housing Finish.
 - Extension units will only use 1-1/4" fork size.
 - Available on Advanced units only.
 - Maximum extension length is 180 in. (4.6 m), minimum length is 3 in. (7.6 cm). Length cannot be zero.

ELECTRONICS REMOTE

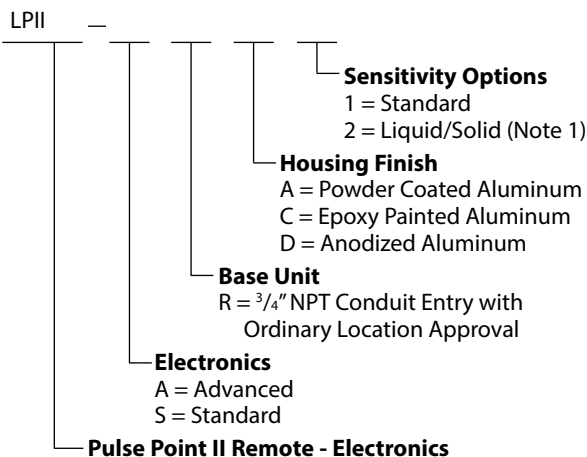

Note 1: Liquid/Solid Interface is available with Advanced Electronics only.

REMOTE DIMENSIONS

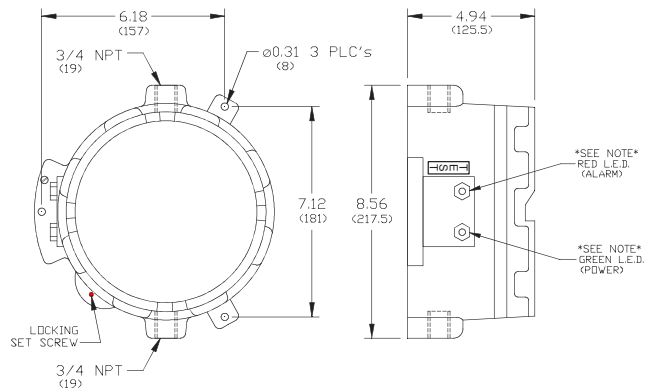

SPECIFICATIONS

FUNCTIONAL

Power Requirements Universal	(± 10%), 120-240 VAC 50/60 Hz or 24-48 VDC
Power Consumption - STANDARD	10 W AC; 3 W DC
Power Consumption - ADVANCED	11 W AC; 4 W DC
Fuse	Fast Blow, 1 A 300 V (Not User Serviceable)
Operating Temperature	
Electronics	-40° to 158° F (-40° to 70° C)
Fork	-55° to 302° F (-48° to 150° C) depending on fork
Outputs	
Main Relay	8 A DPDT @ 240 VAC or 30 VDC (resistive)
Auxiliary Relay - ADVANCED Only	0.46 A SPDT @ 150 VAC or 1 A @ 30 VDC

PERFORMANCE

Pressure Rating	150 psi (10.5 kg/cm ²) with 1-1/2" NPT; 5 psi (0.35 kg/cm ²) with mounting plate
Time Delay - STANDARD	Field Adjustable; 1 - 6 seconds
Time Delay - ADVANCED	Field Adjustable; 0 - 150 seconds
Fail Safe	Field Selectable; high/low level
Sensitivity - STANDARD	Minimum 2.0 lbs/ft ³ (32 kg/m ³); Field Adjustable
Sensitivity - ADVANCED	Minimum 0.5 lbs/ft ³ (8 kg/m ³); Field Adjustable
Maximum Particle Size	3/8" (9.5 mm)

PHYSICAL

Enclosure Material	Polyester, Epoxy Coated Aluminum, or 304 SS
Fork Material	316 SS (standard); 316 SS with Teflon® coating
Dual Conduit Entry	3/4" NPT or M20 x 1.5
Mounting Plate Material	Mild Steel, 304 SS
Extended Pipe Material	Galvanized or 316 SS
Shipping Weight	Integral, non-extended 10 lb (4.5 kg)

AGENCY APPROVALS

UL (US and Canada)

- Ordinary Location, Type 4X; IP66

CE

- Electromagnetic Compatibility Directive
- Low Voltage Directive

