

PNEU-CON

**PNEUMATIC
CONVEYING, INC.**



SC 2000 PR3C



SC 2000 VP

WHISPER[®] LOADERS

WHISPER® LOADERS

Self-Contained Vacuum Loaders

Whisper Loaders™ are self-contained vacuum conveying systems which operate automatically to maintain a constant material level in day bins or a receiving hopper, which can be located above injection, extrusion or blow molding machines.

Each self-contained system operates on a batch principle. They come with an adjustable timer for conveying, and with a proximity switch to initiate the process.

With 0.25 to 4.25 cubic ft. capacities, Whisper Loaders can also be outfitted for Gravimetric operations. Adding a high-level probe and slide gate will allow you to refill with a signal from a feeder.

FEATURES

- Automatic high level control of the process hopper is accomplished by the proximity switch.
- 120 Volt power, prewired with cords.
- NEMA 1 Control panel, Solid State PLC controller with adjustable timers, indicator lights and built-in circuit breaker.
- Tool-less lid removal for filter maintenance.
- Sound attenuation cone, (standard on SC1500 and SC1750 models)
- 10 to 20 feet of flexible hose, depending on model.

SC1250 Whisper Loader

Rates up to 250 lbs per hour*
The most compact unit in the Whisper Loader line, SC1250 is ideal for smaller molding & extrusion machines.



A taller version of SC1250, SC1250XT (extra tall), is available.

SC1500 Whisper Loader

Rates up to 1000 lbs per hour*
The size of SC1500 offers greater versatility than our smaller SC1250 unit, and an option for Proportional loading with Interblend.



SC1750 Whisper Loader

Rates up to 1500 lbs per hour*
Deceptively robust and capable of larger rates, this unit is ideal for mid-size injection and molding machines.



SC2000 Whisper Loader

Rates up to 2200 lbs per hour*
For more than just molding or extrusion machines, SC2000 also meets the demands for grinding, roasting & packaging applications.



SC2500 Whisper Loader

Rates up to 3500 lbs per hour*
The powerhouse of the Whisper loader line, SC2500 can convey large amounts of material at distances up to 40 linear feet.



Remote Control Panels



Remote mounted electrical control panels are standard on Models SC1500, SC1750, SC2000 and SC2500. Control panels are optional on Model SC1250.

All brands of PLC Controls such as Allen-Bradley, Square D and others are also available.

Consult factory for control panel options.

OPTIONS

- Available in Pellet, Vibra-Pulse or Powder orientation.
- 120 or 240 Volt power.
- NEMA 12, 4 and 4X hinged enclosures.
- Variable speed controller.
- Flanged discharge for batch/gravimetric applications.
- Proportional loading of two (2) products with Interblend.
- Available in Aluminum, Carbon steel, 304 & 316 Stainless steel.

Portable Feed Bin Hoppers

Feed Bin / Bulk Material Hopper

Depending on the application, we offer optional portable feed bin hoppers to conveniently load bulk material into the conveyance flow.



Vibra-Pulse™

Automatic Filter Cleaning System

Built into the loader cover assembly, Vibra-Pulse offers continuous timed-cycle pulse-jet cleaning. A variety of filter media options are available.

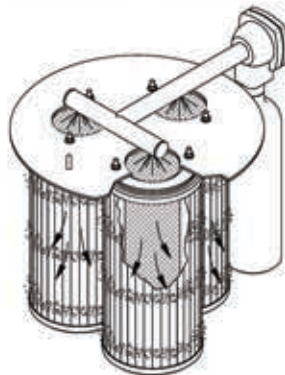

Filter Media Options

Cartridge and Flat/Disc Filters

12" to 48" pleated cartridge filters are available. Tubesheet mounted & lightweight for easy removal. Also available are a variety of flat/disc filters.



Proportional Loader Operating Sequence with Interblend

Proportional Loaders allow for the alternate conveying of two (2) different materials. Interblend is a static internal blender used to prevent layering in a proportioning loader.

1. The ratio selection of virgin and regrind is a direct reading from 0 to 100%. The total cycle time is factory preset and may be field adjusted to compensate for conveying distance.

Adjustment of the cycle time does not alter the ratio adjustment. With switch "on" and no material sensed in the receiving hopper, virgin is loaded.

2. After the virgin material requirement is reached, regrind is loaded.

3. "Off time" allows material to dump or discharge. Materials are blended as they are discharged.

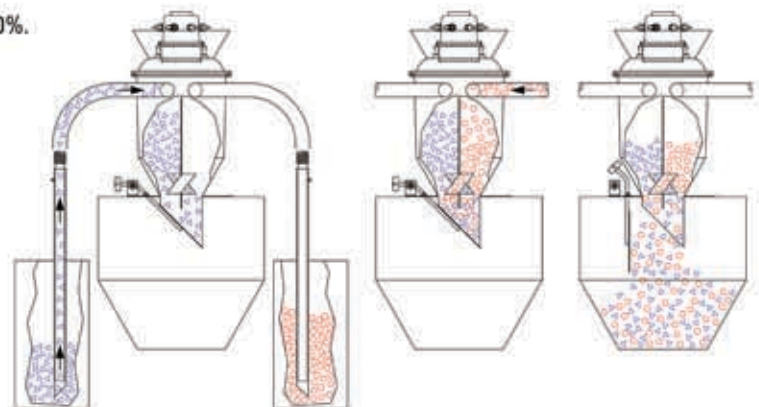

SELF-CONTAINED UNITS

PROPORTIONAL LOADERS (PLVP): The Vibra-Pulse Automatic Filter Cleaning System consumes .5 SCFM @60 PSI of dry, filtered compressed air for each cycle. (Compressed air source not included). All loaders are equipped with VP cleaning systems.

POWDER RECEIVERS (PR): 6" TO 24" Pleated cartridge filters for powder and fine product handling. PR1C are used on SC1250, PR3C for SC1500, SC1750 and SC2000. PR4C for SC2500.

All of Pneu-Con's self-contained loaders are available in Aluminum, 304, 316 Stainless Steel, and Carbon Steel.

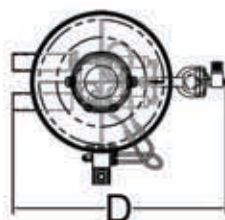
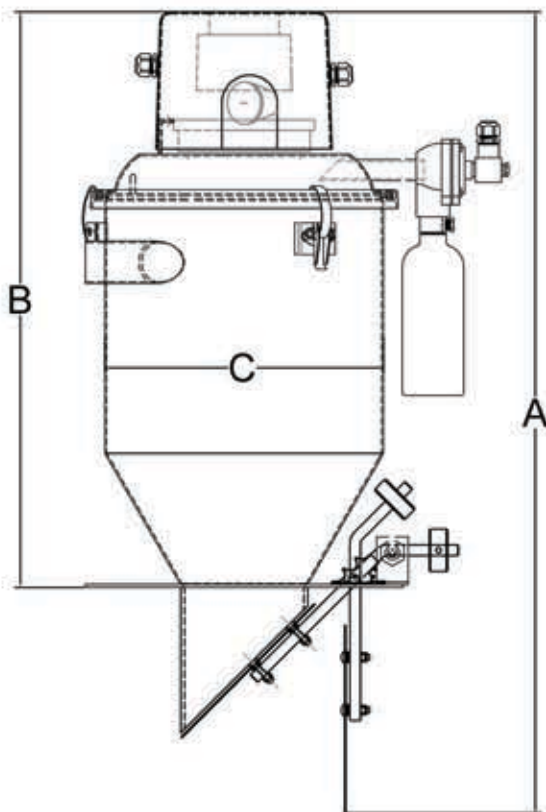

PROPORTIONAL LOADERS (PLVP) *

PLVP: Proportional loaders allow for the alternate conveying of two (2) different materials (Dual Inlet).

DUAL INLET / INTERBLEND (IB) *

IB: Interblend is a static Internal Blender used to prevent layering within proportional loaders.

* Available in all Pneu-Con self-contained loaders.

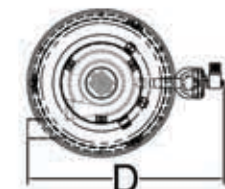

SEMI TE / STD / DI-AC

Di-Ac (Diaphragm Action) automatic filter cleaning action. Flexible screen that separates pellet-like material from conveying air.

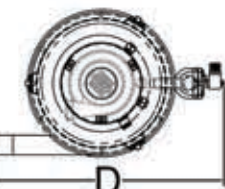

BOX TE

Box TE allows for convenient conveying of delicate products (seeds etc.)

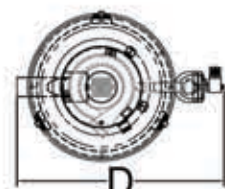

DEFLECTOR

Deflectors are generally used to convey heavy products through the convey lines.

MODEL #	DIMENSIONS IN INCHES				ORIENTATION AND OPTIONS						
	A	B	C	D	Di-Ac	Felt	Cartridge	Dual Inlet	IB	TE	BTE
SC1250	20.7500	11.7500	8.2500	13.3750	X	X				X	X
SC1250PR1C	35.5625	29.0000	8.0000	14.0000			X			X	X
SC1250XT	24.6250	18.4375	8.2500	14.0000	X	X	X			X	X
SC1250PLVP*	24.6250	11.7500	8.2500	13.5625	X	X	X	X	X		
SC1500	31.4375	20.7500	13.0000	18.2500	X	X				X	X
SC1500PR3c	43.0000	32.8125	13.1875	21.4375			X			X	X
SC1500Plvp*	31.0000	20.3125	12.6250	18.3750	X	X	X	X	X		
SC1750	31.8125	21.1875	13.0000	18.2500	X	X				X	X
SC1750PR3C	43.7500	30.0625	13.0000	20.5000			X			X	X
SC1750PLVP*	37.6250	27.0000	13.0000	21.8750	X	X	X				
SC2000	37.7500	27.2500	13.1250	18.2500		X				X	X
SC2000PR3C	44.0000	33.0000	13.1250	21.7500			X			X	X
SC2000PLVP*	37.7500	27.2500	13.1250	21.7500		X	X	X	X		
SC2500	52.8125	42.2500	18.1875	26.2500		X				X	X
SC2500PR4C	52.8125	42.2500	18.1875	26.2500			X			X	X
SC2500PLVP*	52.8125	42.2500	18.1875	26.2500		X	X	X	X		